

# DISPOZIČNÍ VÝKRES MODULU LÁVKY

M 1:25

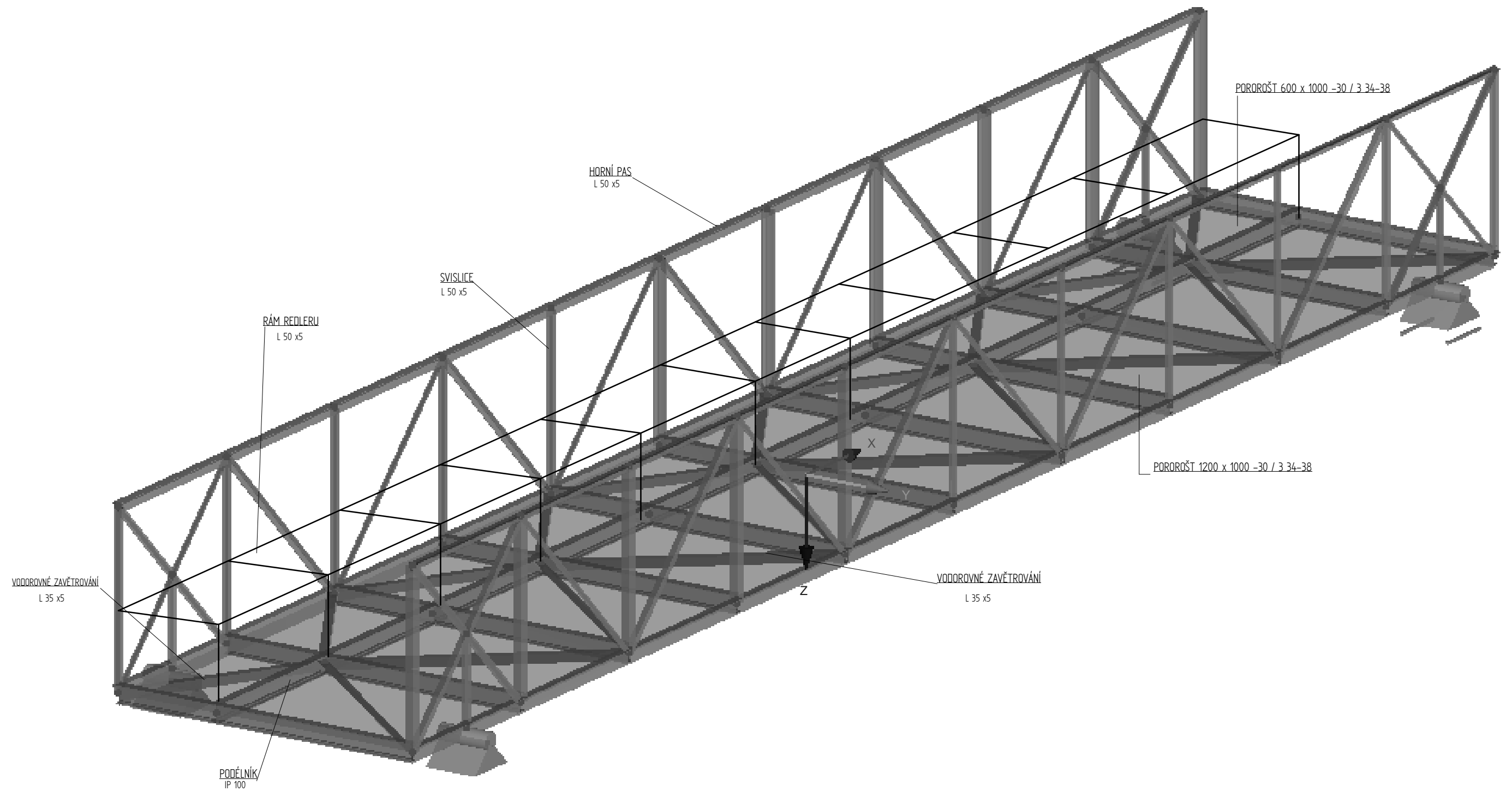

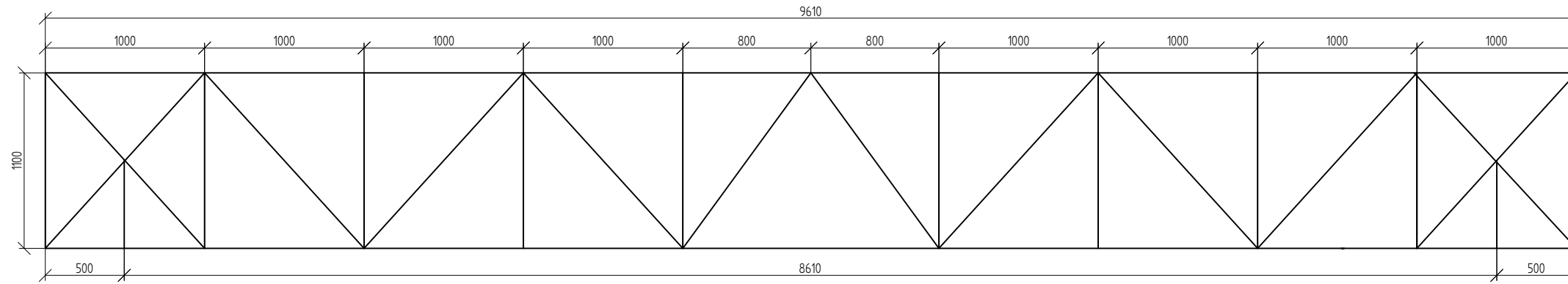
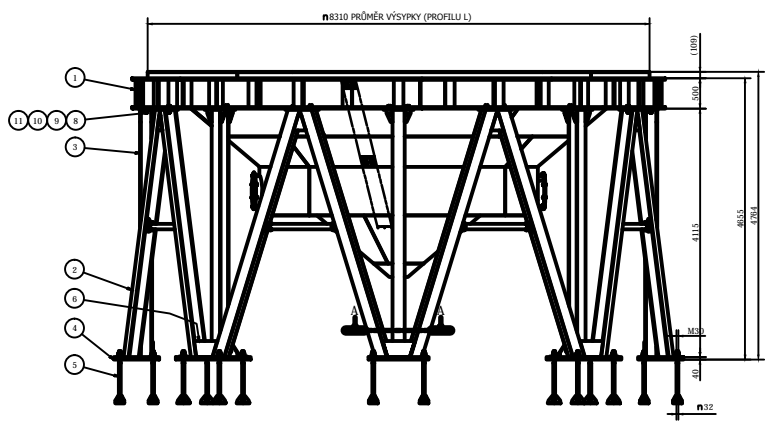

B-B (1 : 30)

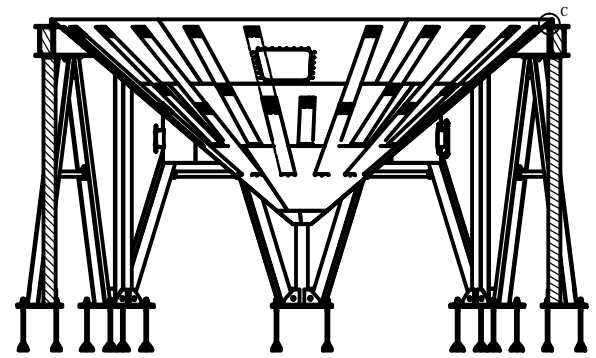

A-A (1 : 5)

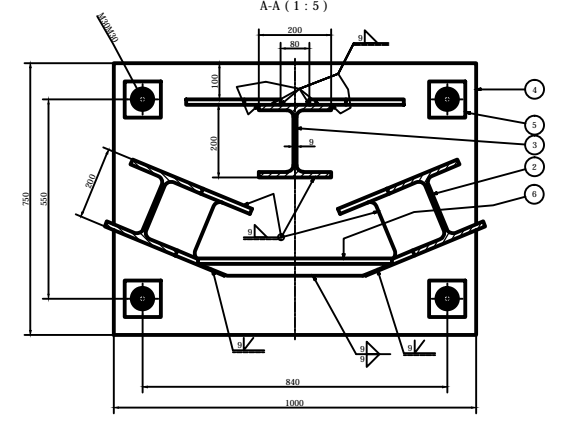

C (1 : 2)

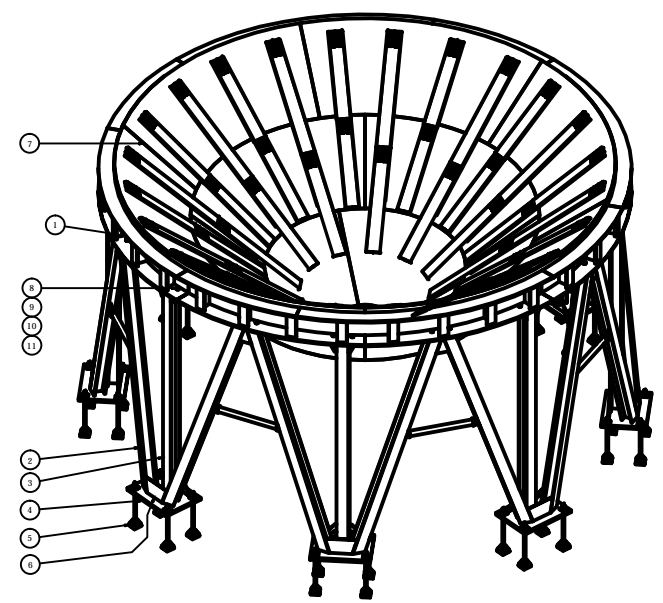
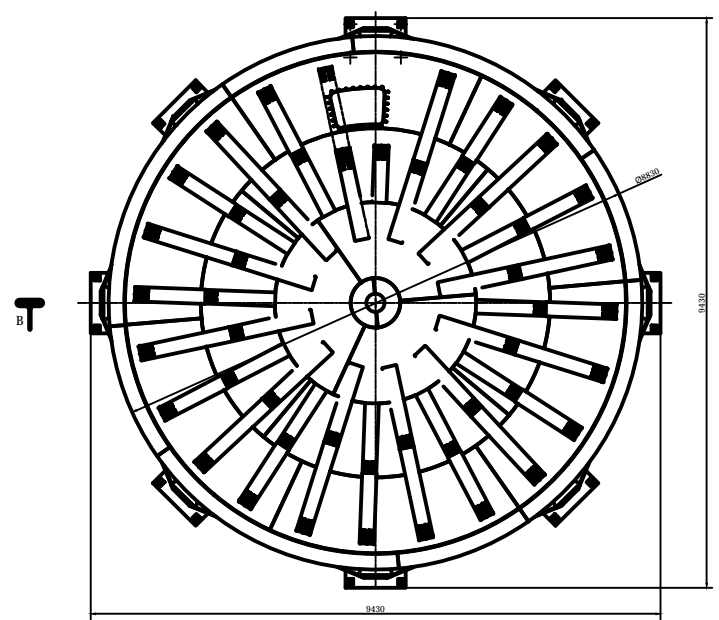
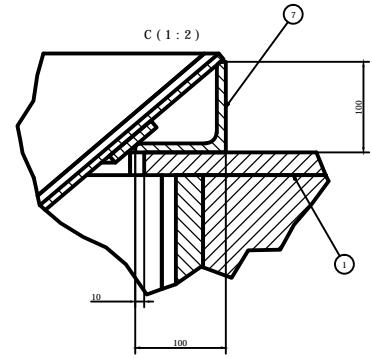

VÝŠYPKA JE VOLNĚ POLOŽENA NA NOSNÝM PRSTENCI.  
POLOHU VÝŠYPKY URČIT PŘI MONTÁŽI.

11	ISO 4032 - M24	0,13	32
10	DIN 128 - A24	0,02	32
9	DIN 125 - A 75	0,07	64
8	DIN 933 - M24 x 100	0,48	32
7	VÝŠYPKA	MM VYS-000-020	3578,06
6	PLEČI	MM PP-000-010-13	14,14
5	KOTVENÍ ŠROUB	MM PP-000-013	11,64
4	KOTVENÍ DESKA	MM PP-000-012	244,49
3	PODPERA 2	MM PP-000-011	278,44
2	PODPERA 1	MM PP-000-010	597,48
1	NOSNÝ PRSTENEC	MM-NP-000-001	1833,32
ROZMĚRY		ČÍSLO SOUČÁSTI	HMOTNOST
M1:30		Číslo výkresu: MM-OK-000	
		JK S VÝŠYPKOU	1/1



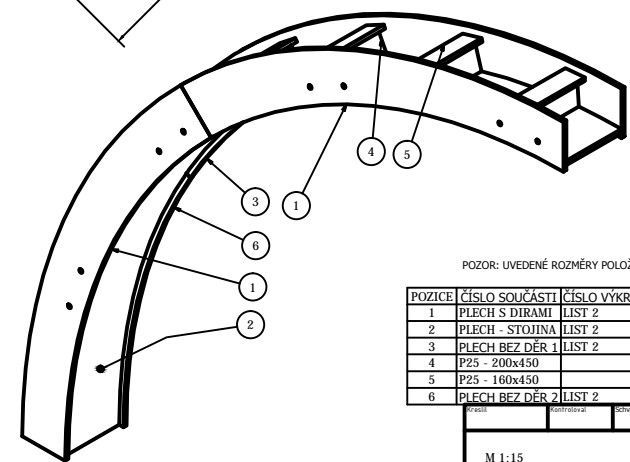
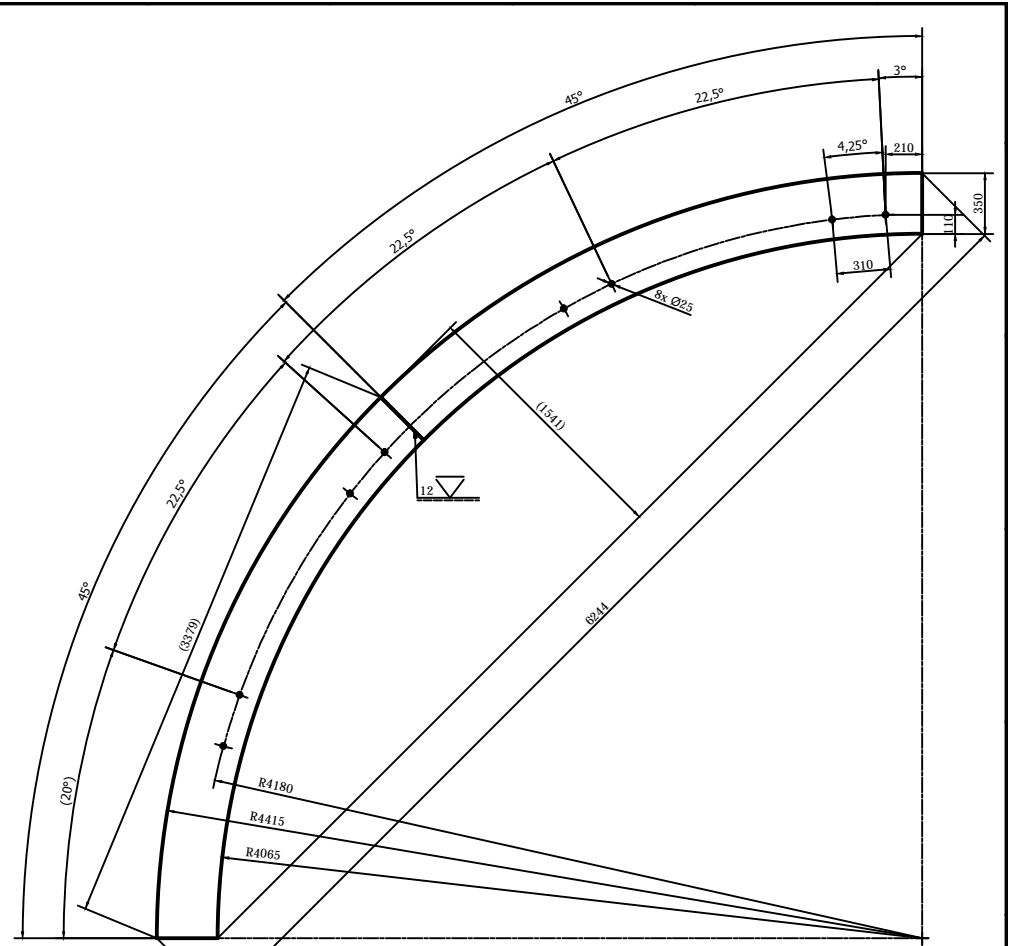
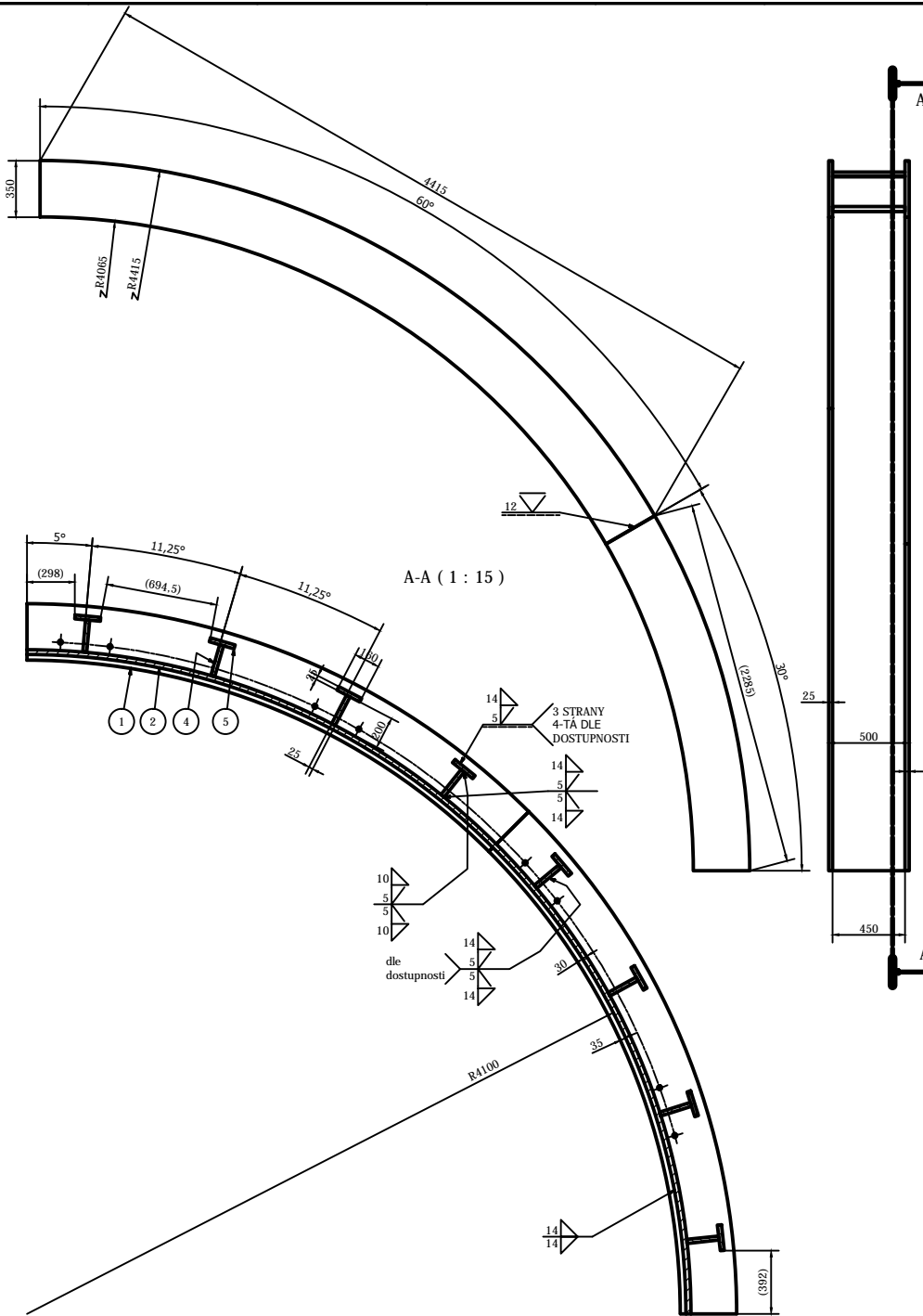

POZOR: UVEDENÉ ROZMĚRY POLOŽEK NA VÝKRESU NEUVAŽUJÍ S PŘÍPRAVOU PRO SVARE

POZICE	ČÍSLO SOUČÁSTI	ČÍSLO VÝKRESU	NORMA	MATERIÁL	HMOTNOST	KS
1	PLECH S DIRAMI	LIST 2	CSN 42 5310	S 355	228.35	2
2	PLECH - STOJINA	LIST 2	CSN 42 5310	S 355	685	1
3	PLECH BEZ DĚR	LIST 2	CSN 42 5310	S 355	304.98	1
4	P25 - 200x450		CSN 42 5310	S 355	17.66	8
5	P25 - 160x450		CSN 42 5310	S 355	14.13	8
6	PLECH BEZ DĚR	LIST 2	CSN 42 5310	S 355	152.49	1

Projekt	Projektant	Schválil - dle	Datum	Dělník
			2.4.2015	
M 1:15			Číslo výkresu: MM-NP-000-001	
NOSNÝ PRSTENEC			Wydání	1/1

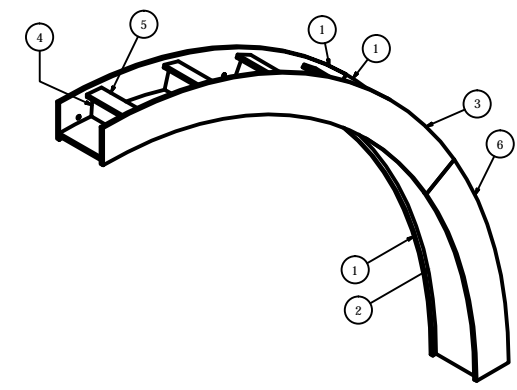
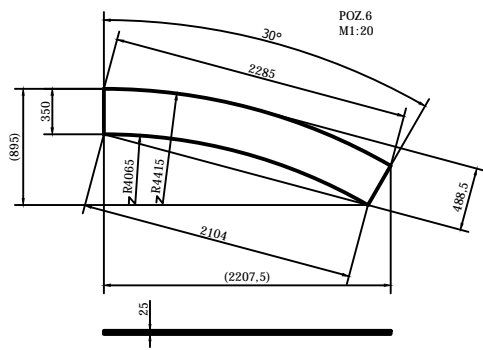
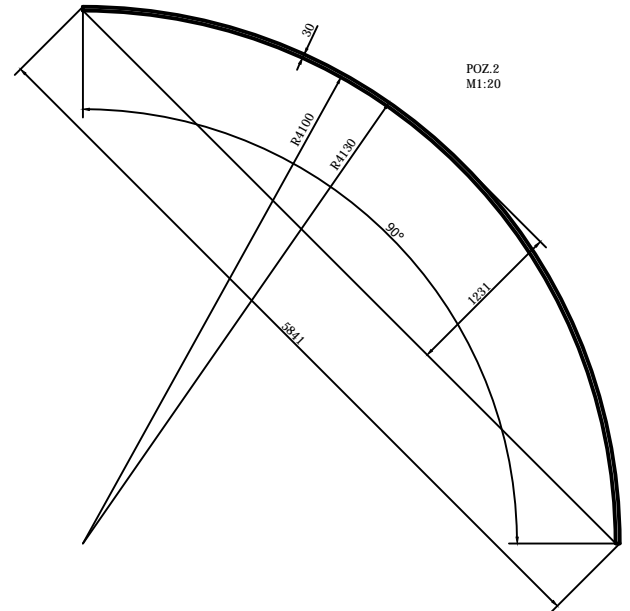
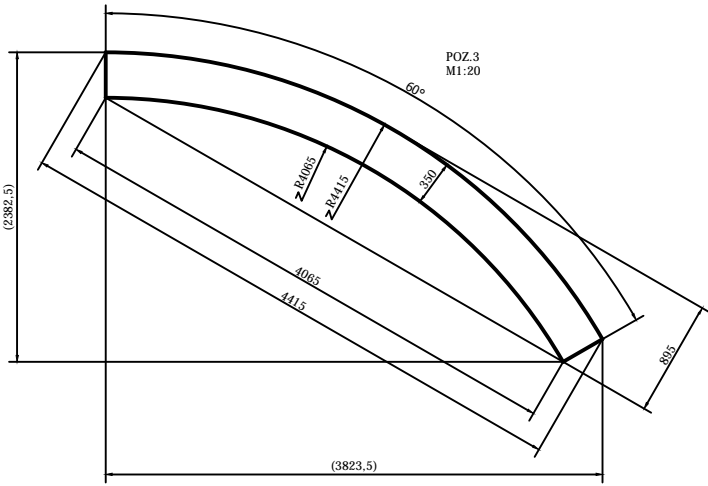
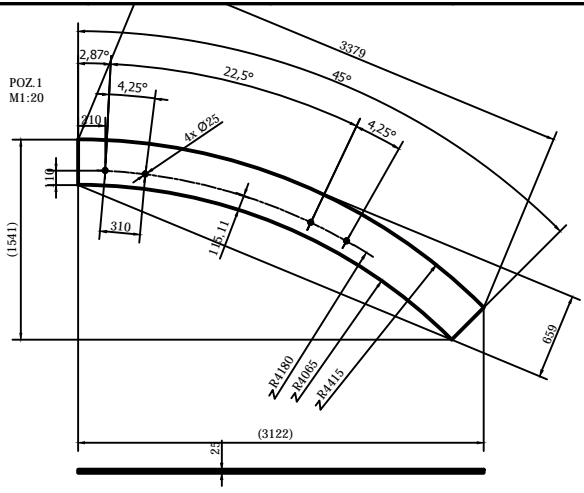

/ POZ.2  
M1:20

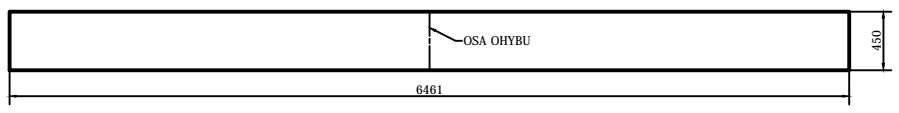

Projekt	Kontrola	Schvál - die	Datum	Dělník
			2.4.2015	
Číslo výkresu: MM-NP-000-001				Str.
NOSNÝ PRSTENEC				2 / 2

# DISPOZIČNÍ VÝKRES LÁVKY

M 1 : 25

